



MUVIQ USA, LLC.

MUVIQ SLP, S.A de C.V

**Supply Chain Security Guidelines for Vendors,  
Suppliers and Service Providers**

in accordance with the U.S. Customs and Border Protection C-TPAT Program.





## Supply Chain Security Guidelines for Vendors, Suppliers and Service Providers

### Overview

In the interests of securing MUVIQ USA, LLC, its shipments and its international supply chain, the company has initiated the implementation of supply chain security guidelines in line with U.S. Customs and Border Protection C-TPAT requirements.

The Customs-Trade Partnership Against Terrorism (C-TPAT) is a voluntary supply chain security program led by U.S. Customs and Border Protection (CBP) and focused on improving the security of private companies' supply chains with respect to terrorism, smuggling and any other illicit activity.

As a certified member, MUVIQ USA, LLC is required to ensure that all of its business partners adopt security-minded strategies and procedures that meet the C-TPAT requirements. This applies to any new supplier or vendor interested in becoming a business partner and part of the MUVIQ USA, LLC supply chain.

Certified importers that outsource elements of their supply chain, such as foreign facilities, conveyances and domestic warehouses are required to assess and monitor their business partners' security protocols according to U.S. Customs C-TPAT criteria.

### Business Partners C-TPAT Expectations

- The Acknowledgment Form on the last page of these Supply Chain Security Guidelines must be signed by a company officer (i.e. General Manager, Plant Manager, etc...) and returned to MUVIQ USA, LLC within **three (3) weeks** of receipt of this document.
- Suppliers must ensure that employees are aware of all required security protocols and must ensure that systems are in place to foster compliance.

## 1. Container Security

All business partners transporting, handling, shipping or processing shipments for, or on behalf of, MUVIQ USA, LLC. are required to abide by the following requirements:

### A. Container Inspection:

All containers selected to transport MUVIQ USA, LLC cargo must be inspected according to the standards outlined by MUVIQ USA, LLC and by U.S. Customs and Border Protection.

The container inspection must be conducted prior to loading cargo for MUVIQ USA, LLC (see Figure 1)

- Front wall
- Left side
- Right side
- Floor
- Ceiling/Roof
- Inside/outside doors
- Outside/Undercarriage



Figure 1

For trailers and tractors:

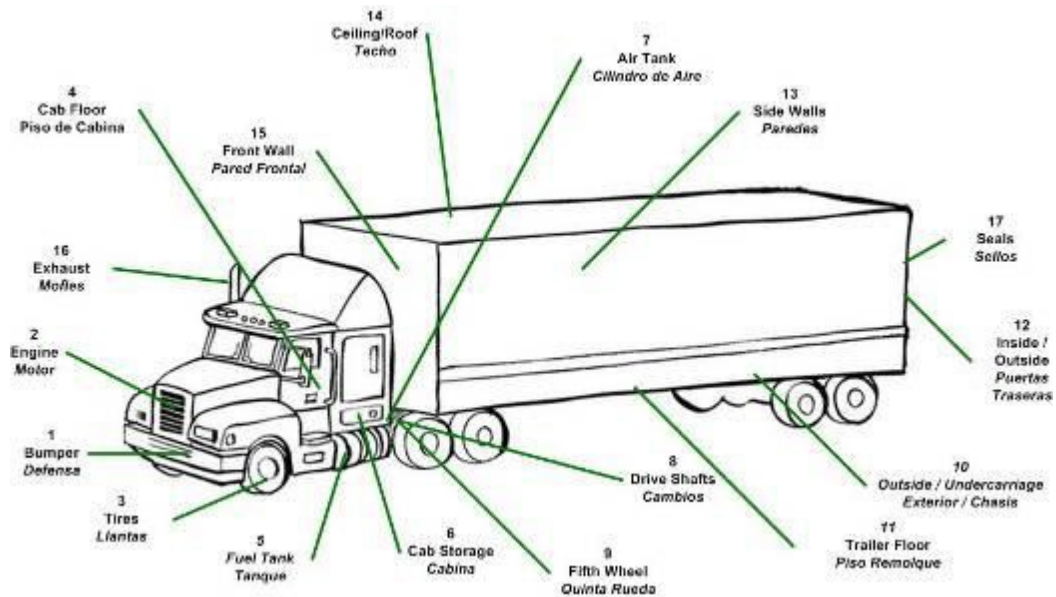

Figure 2

The appropriately designated employee must conduct the inspection immediately prior to the stuffing of the container.

The inspection of the empty container must be documented on a Physical Inspection Checklist. **See *sample Inspection Checklist* below.**

The selection of the empty container must be done by the contracted carrier's designated representative.

NOTE: If any container selected to transport cargo for MUVIQ USA, LLC shows signs of tampering or damage, it must be immediately rejected, and the appropriate personnel must be notified.

## Inspection Checklist

<b>Date / Fecha</b>		<b>Driver's Name / Nombre chofer</b>	
<b>Time of Arrival / Tiempo de entrada</b>		<b>Time of Exit / Tiempo de salida</b>	
<b>Tractor Number / No. de Tractor</b>		<b>License Plates / No. de placas</b>	
<b>Trailer Number / No. de caja</b>		<b>License Plates / No. de placas</b>	
<b>Seal Number / No. de sellos</b>		<b>Seal Number / No. de sellos</b>	
<b>Area of Inspection / Concepto</b>	<b>OK</b>	<b>NO</b>	<b>Observations / Observaciones</b>
1. <b>Bumper / Defensa</b>	<input type="checkbox"/>	<input type="checkbox"/>	
2. <b>Engine / Motor</b>	<input type="checkbox"/>	<input type="checkbox"/>	
3. <b>Tires / Llantas</b>	<input type="checkbox"/>	<input type="checkbox"/>	
4. <b>Cab Floor / Piso de Cabina</b>	<input type="checkbox"/>	<input type="checkbox"/>	
5. <b>Fuel Tank / Tanque</b>	<input type="checkbox"/>	<input type="checkbox"/>	
6. <b>Cab Compartments / Cabina</b>	<input type="checkbox"/>	<input type="checkbox"/>	
7. <b>Air Tank / Cilindros de aire</b>	<input type="checkbox"/>	<input type="checkbox"/>	
8. <b>Drive Shafts / Cambios</b>	<input type="checkbox"/>	<input type="checkbox"/>	
9. <b>Fifth Wheel / Quinta rueda</b>	<input type="checkbox"/>	<input type="checkbox"/>	
10. <b>Outside &amp; Undercarriage / Exterior &amp; Chasis</b>	<input type="checkbox"/>	<input type="checkbox"/>	
11. <b>Trailer Floor / Piso remolque</b>	<input type="checkbox"/>	<input type="checkbox"/>	
12. <b>Inside Outside Doors / Puertas Traseras</b>	<input type="checkbox"/>	<input type="checkbox"/>	
13. <b>Side Walls / Paredes</b>	<input type="checkbox"/>	<input type="checkbox"/>	
14. <b>Ceiling / Roof Techo</b>	<input type="checkbox"/>	<input type="checkbox"/>	
15. <b>Front Wall / Pared frontal</b>	<input type="checkbox"/>	<input type="checkbox"/>	
16. <b>Exhaust / Mofles</b>	<input type="checkbox"/>	<input type="checkbox"/>	
17. <b>Seals / Sello de seguridad</b>	<input type="checkbox"/>	<input type="checkbox"/>	
<b>Name of employee / Nombre de inspector</b>		<b>Signature / Firma</b>	
<b>Time of Inspection / Tiempo de inspeccion (ejemplo 12:15pm)</b>			

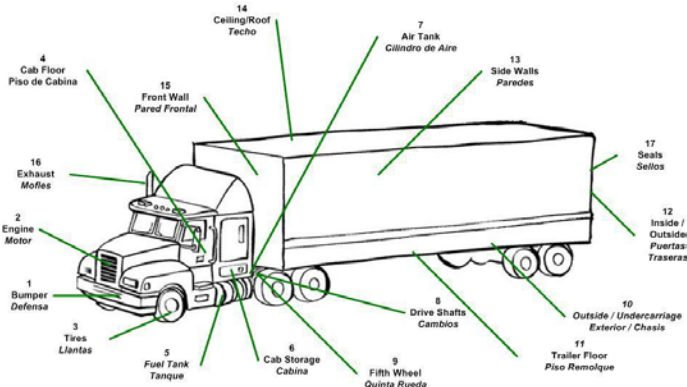

September 2016



## 2. Container Seals

### A. Placement

All containers loaded with MUVIQ USA, LLC cargo must be secured with an ISO- 17712 high security seal immediately after loading.

Only the designated and authorized supplier representative must have access to the seals that are destined to be placed on MUVIQ USA, LLC containers.

Responsibility for the application and integrity of the seal is with the contracted carrier's representative.

The supplier must be responsible for securing all seals destined to be placed on MUVIQ USA, LLC containers.

Any identified discrepancy or anomaly must be immediately investigated.

It is the responsibility of the supplier to provide MUVIQ USA, LLC with the correct seal number through the contracted freight forwarder and/or carrier.

Any anomaly regarding the seals must be communicated to the freight forwarder and/or carrier and subsequently to MUVIQ USA, LLC.

The supplier must provide the contracted freight forwarder and/or carrier with all of its guidelines pertaining to the seals. These guidelines must cover the following:

- Seal location and storage.
- Seal placement
- Seal discrepancy procedures.
- Transmission of information to other entities (freight forwarder or customs broker)

It is the policy of MUVIQ USA, LLC to only conduct business with C-TPAT certified or C-TPAT compliant service providers (freight forwarders, carriers, US Customs brokers, drayage and shipping lines).

The seal must meet or exceed the current PAS/ISO 17712 standards. It must be a bolt seal or a cable seal (see Figure 3). MUVIQ USA, LLC will not accept any other type or lower rated seal to be placed on its shipments.



Figure 3

MUVIQ USA, LLC requires that all of its containers to be secured with a high security seal.

In the case of an inspection from a foreign Customs official or any other government agency that requires the seal to be broken, a second high security seal must be affixed immediately after the Customs inspection and documented on paperwork.

On cargo transported by tractor-trailers, the spare seal(s) must be placed in a shipping document pouch affixed on the inside wall of the trailer.

The seals must be placed on the right door of the container on the hasp that has the welded rivet.

Once placed, the integrity of the seal must be tested by utilizing the V.V.T.T method.

## B. V.V.T.T. Method

The integrity of each of the affixed high security seals must be verified by implementing the following steps (Figure 4):

- **V**iew the seal
- **V**erify the seal
- **T**ug on the seal
- **T**ug & Twist the seal



Figure 4





Any identified anomaly must be immediately documented and reported.

**C. Responsibility**

The responsibility of the freight forwarder and/or carrier is to ensure that all the information and data pertaining to the seal is transmitted in a timely manner.

**D. Seal Custody**

All seals destined to be affixed to MUVIQ USA, LLC containers must be secured, and access must be limited to authorized personnel at all times.

A seal log must be used to track and document all seals placed on MUVIQ USA, LLC containers departing from the supplier's facility, factory or warehouse.

**E. Reporting Anomalies**

It is the responsibility of the freight forwarder and/or carrier representative to report any anomalies to MUVIQ USA, LLC. MUVIQ USA LLC will then investigate any reported anomaly and will take the necessary actions (contacting the Port Authority, local Customs services, U.S. Customs and Border Protection, or appropriate local authorities).

**3. Container Storage**

Containers located in a facility of the foreign business partner (consolidation terminal, truck yard or port area) must be stored in a secure area to prevent unauthorized access and/or manipulation.

Procedures must be in place for reporting any detected, unauthorized entry into containers or container storage areas to appropriate local law enforcement officials.

**4. Physical Access Controls**

Any facility handling MUVIQ USA, LLC cargo must have effective access controls in place. Facility management must be able to limit and maintain control over who has access to the facility and to MUVIQ USA, LLC cargo and shipments.

**A. Employees**

Basic procedures must be in place to identify employees assigned to handling and loading of cargo on behalf of MUVIQ USA, LLC.

**B. Visitors**

Access to MUVIQ USA, LLC cargo and shipment must only be granted to authorized personnel and representatives.



## **5. Personnel Security**

### **A. Pre-employment:**

Application information, such as employment history and references must be verified prior to employment for all employees.

### **B. Termination Procedures**

All vendors, suppliers or service providers must have procedures in place to remove identification, facility, and system access for terminated employees handling cargo on behalf of MUVIQ USA, LLC.

## **6. Procedural Security**

### **A. Cargo Controls**

All MUVIQ USA, LLC cargo must be tallied and documented by an authorized employee of the supplier's site.

All shortages, overages, and other significant discrepancies or anomalies must be resolved and/or investigated appropriately. The cargo discrepancy must be reported to MUVIQ USA, LLC.

### **B. Shipping and Receiving**

Arriving cargo should be reconciled against information on the cargo manifest. The cargo should be accurately described, and the weights, labels, marks and piece count indicated and verified. Cargo should be verified against purchase or delivery orders.

All drivers arriving or departing the supplier's site must be positively identified.

If a driver cannot be positively identified or is unknown to the supplier, access to the facility must be denied and the contracted carrier management must be notified.

## **7. Security Training and Awareness**

A security awareness program should be established and maintained by vendors, suppliers or service providers to recognize and foster awareness of security vulnerabilities to MUVIQ USA, LLC supply chain.

On an annual basis, employees handling, loading or monitoring MUVIQ USA, LLC cargo must be made aware of the procedures which the vendor, supplier or service provider has in place to report a security concern or incident.

## **8. Physical Security**

MUVIQ USA, LLC vendors, suppliers or service providers shall implement procedures to prevent unauthorized personnel from gaining access to the facility or the holding/storage area containing MUVIQ USA, LLC Cargo, trucks, containers, or vessels. The following procedures shall be implemented

to prevent tampering with cargo conveyances while they are in the vendor, supplier or service provider's custody:

**A. Fencing**

Perimeter fencing should enclose the area around cargo handling and storage facilities, container yards, and terminals. All fencing must be regularly inspected for integrity and damage.

**B. Gates and Gate Houses**

Gates through which vehicles and/or personnel enter or exit must be manned and/or monitored and secured when not in use.

**C. Parking and Private Vehicles**

Access to terminals by private passenger vehicles should be limited as much as possible in order to lessen opportunities to introduce contraband into the terminal area or to remove items from the facility.

If access is given to private passenger vehicles, they should be prohibited from parking in or adjacent to cargo handling and storage areas, and vessels.

**D. Building Structure**

Buildings must be constructed of materials that resist unlawful entry. The integrity of structures must be maintained by periodic inspection and repair.

**E. Locking Devices and Key Controls**

All external and internal windows, gates and fences must be secured with locking devices. Management or security personnel must control the issuance of all locks and keys.

**F. Lighting**

Adequate lighting must be provided inside and outside the facility including the following areas: entrances and exits, cargo handling and storage areas, fence lines and parking areas.

**G. Alarms Systems & Video Surveillance Cameras**

At those locations determined appropriate by the carrier's risk assessment, alarm systems and video surveillance cameras should be utilized to monitor premises and prevent unauthorized access to dock and cargo storage areas.

## 9. Information Technology Security

Information Technology (IT) security guidelines should be in place such as password protection and user accountability. If outside technicians or programmers are utilized to work on internal systems, these individuals should be monitored to ensure that sensitive data is not accessed.

### A. Password Protection

Automated systems must use individually assigned accounts that require a periodic change of password. Passwords must be changed at least every 90 days. IT security policies, procedures and standards must be in place and provided to employees in the form of training.

### B. Accountability

A system must be in place to identify the abuse of IT including improper access, tampering or the altering of business data. All system violators must be subject to appropriate disciplinary actions for abuse.

## 10. Reporting Anomalies

Any actual or suspected breach in supply chain security or any breach pertaining to MUVIQ USA, LLC cargo, shipment or paperwork will be immediately reported to identified MUVIQ USA, LLC representative.

Depending of the geographical location of the vendor, supplier or service provider, it is the responsibility of the vendor, supplier or service provider to report any security breach to the appropriate local authorities.



**Vendor, Supplier or Service Provider Acknowledgement Form**

I, \_\_\_\_\_, a duly authorized representative of the above-named company, do hereby acknowledge and confirm the following:

I have received and reviewed a copy of Supply Chain Security Guidelines for Vendors, Suppliers and Service Providers from MUVIQ USA, LLC.

I clearly understand my Company's responsibilities as a MUVIQ USA, LLC Business Partner in ensuring the security and integrity of MUVIQ USA, LLC Supply Chain.

I clearly understand that my Facility may at any time be requested to be the site of MUVIQ USA, LLC and US Customs and Border Protection Validation location. I also clearly understand that I will be notified in advance of this occurring. This (potential) validation at my facility will be to confirm that the requirements of my facility, as listed in this document, are indeed established and being carried out in a consistent manner.

***Please return all reviewed and completed Supplier Security Guidelines to your Commodity Manager and to Erick.Whitten@dayco.com***

\_\_\_\_\_  
Printed Name

\_\_\_\_\_  
Title

\_\_\_\_\_  
Signature

\_\_\_\_\_  
Date

